

# Machine Guard

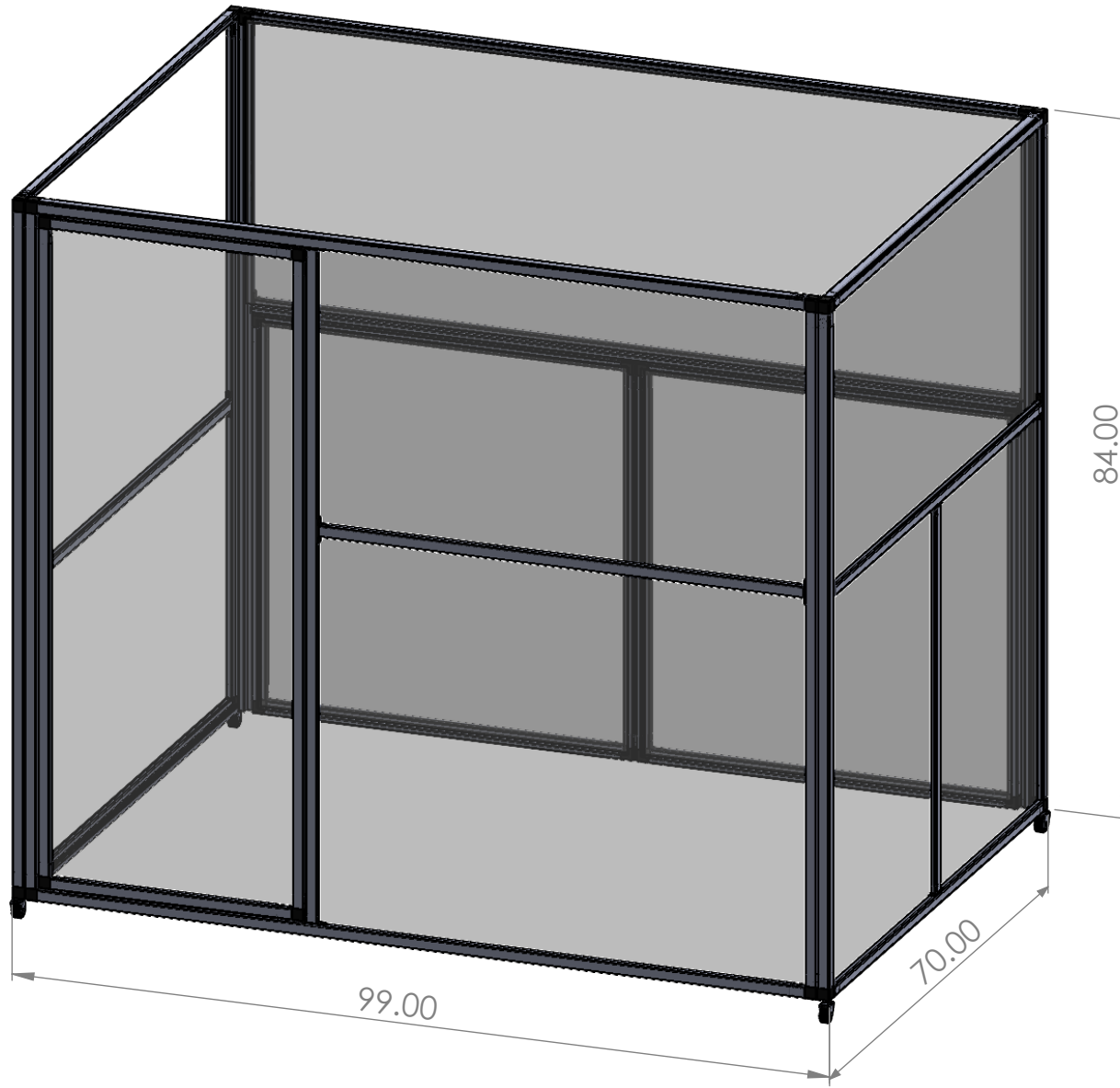

Exploded View

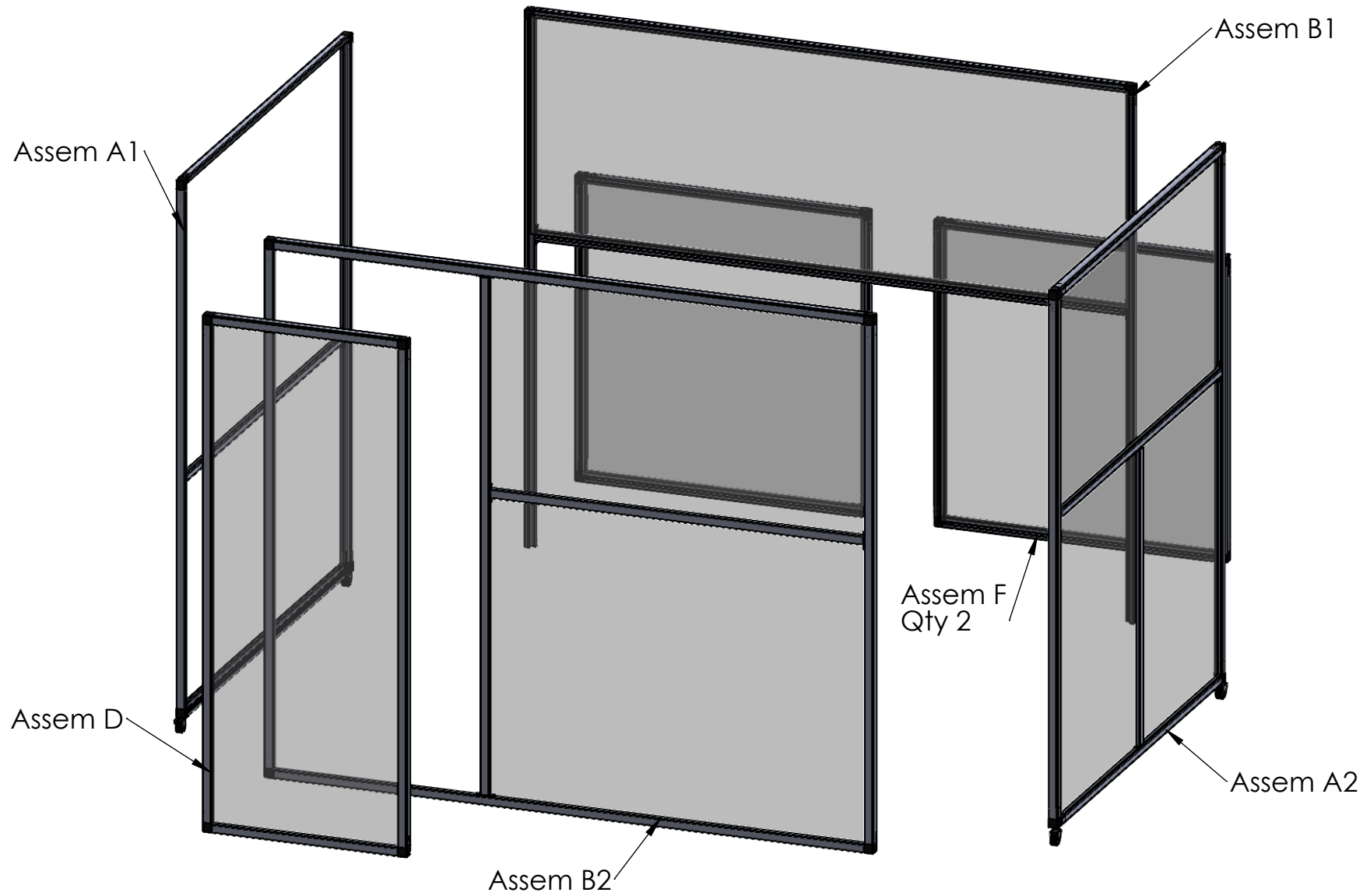

Date: 3-28-22

Description: Machine Guard

Part Number:

Page: 2 Of: 9

Customer:

Drawn by:

**MOXI** ALUMINUM FRAME  
COMPONENTS

5

4

3

2

1

### Assem A

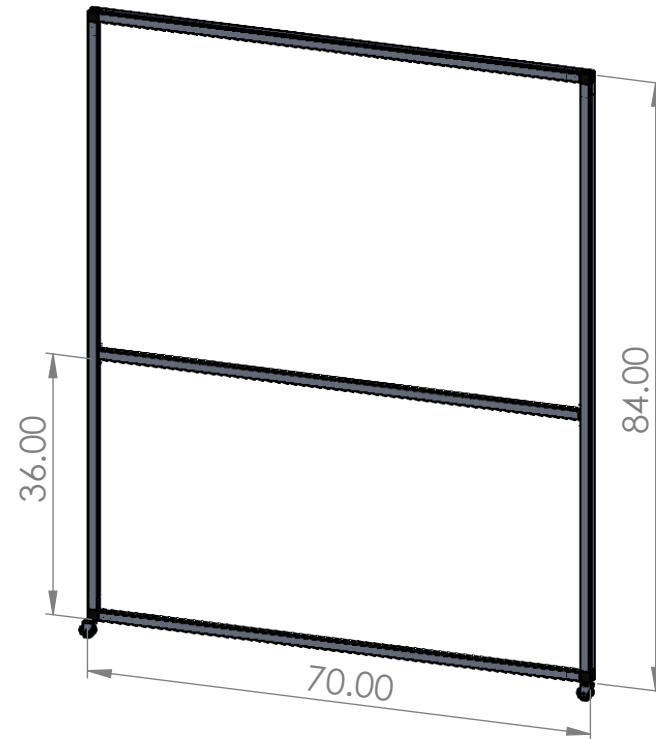

ITEM	QTY.	Part No.	DESCRIPTION	LENGTH (IN)	WIDTH (IN)
1	2	TL1500		67	
2	2	TL1500		81	
3	2	JL2150	2-Way 90 degree corner joint		
4	1	TR1500		66.75	
5	2	JWT150	Winged T		
6	2	CAS200	2 Inch Caster		
7	1	2-Way (Caster Hole A) - JL2150CH1A	2-Way Corner Joint with Caster Hole (A)		
8	1	2 way (Caster Hole B) - JL2150CH1B	2-Way Corner Joint with Caster Hole (B)		

### Assem A2

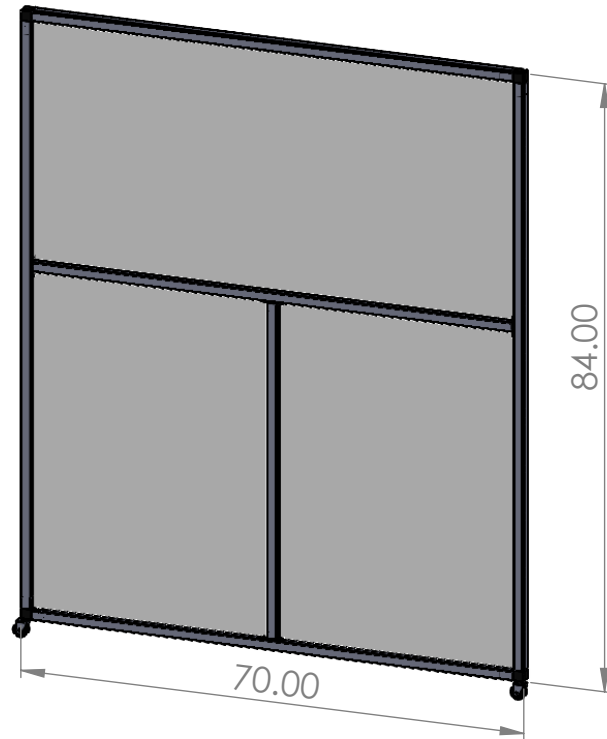

ITEM	QTY.	Part No.	DESCRIPTION	LENGTH (IN)	WIDTH (IN)
1	2	TL1500		67	
2	2	TL1500		81	
3	2	JL2150	2-Way 90 degree corner joint		
4	2	CAS200	2 Inch Caster		
5	1	PAC125-CL	1/8" Acrylic (Clear)	68.38	34.38
6	1	TR1500		66.75	
7	2	JWT150	Winged T		
8	1	TR1500		46.25	
9	2	JWT150	Winged T		
10	1	PAC125-CL	1/8" Acrylic (Clear)	68.38	48.00
11	1	2-Way (Caster Hole A) - JL2150CH1A	2-Way Corner Joint with Caster Hole (A)		
12	1	2 way (Caster Hole B) - JL2150CH1B	2-Way Corner Joint with Caster Hole (B)		

# Assem B1

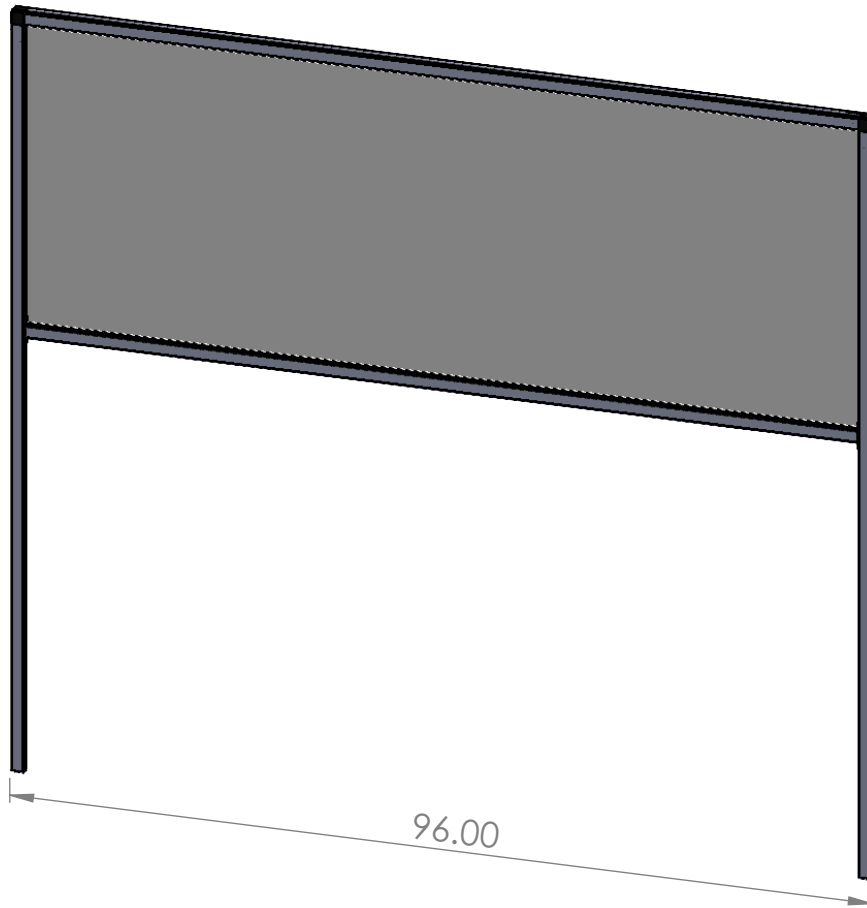

ITEM	QTY.	Part No.	DESCRIPTION	LENGTH (IN)	WIDTH (IN)
1	1				
2	1	TL1500		93	
3	2	TL1500		82.38	
4	1	TL1500		92.75	
5	2	JL2150	2-Way 90 degree corner joint		
6	1	PAC125-CL	1/8" Acrylic (Clear)	94.38	34.38
7	2	JWT150	Winged T		
8	2	JLEC150	End Cap (L-Tube)		

## Assem B2

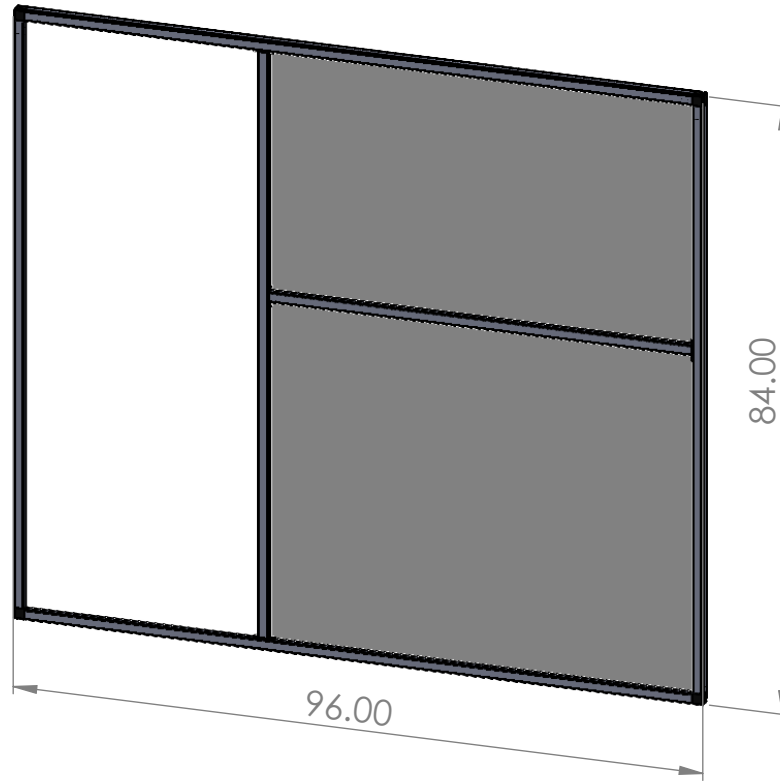

ITEM	QTY.	Part No.	DESCRIPTION	LENGTH (IN)	WIDTH (IN)
1	4	JL2150	2-Way 90 degree corner joint		
2	2	TL1500		93	
3	2	TL1500		81	
4	1	TL1500		80.75	
5	1	TR1500		58.75	
6	1	PAC125-CL	1/8" Acrylic (Clear)	60.38	48.00
7	4	JWT150	Winged T		
8	1	PAC125-CL	1/8" Acrylic (Clear)	60.38	34.38

Assem D

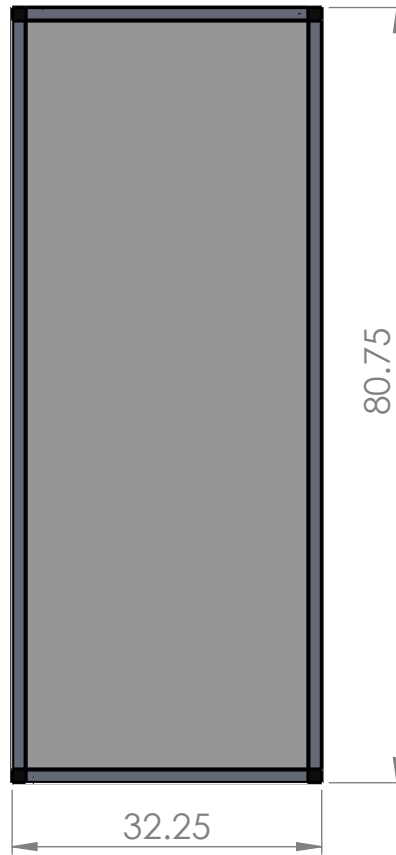

ITEM	QTY.	Part No.	DESCRIPTION	LENGTH (IN)	WIDTH (IN)
1	1				
2	2	TL1500		29.25	
3	2	TL1500		77.75	
4	4	JL2150	2-Way 90 degree corner joint		
5	1	PAC125-CL	1/8" Acrylic (Clear)	79.13	30.63

Assembly F - Qty 2

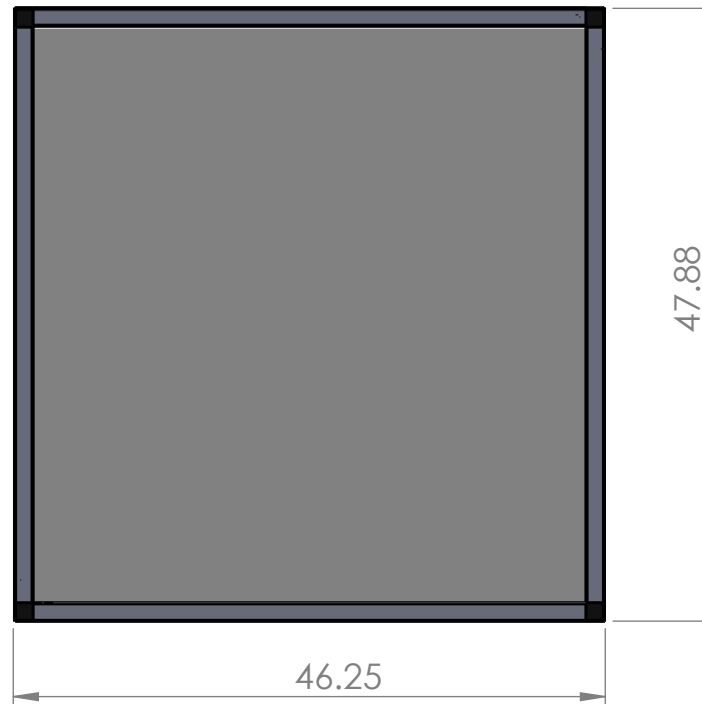

ITEM	QTY.	Part No.	DESCRIPTION	LENGTH (IN)	WIDTH (IN)
1	1				
2	2	TL1500		43.25	
3	2	TL1500		44.88	
4	4	JL2150	2-Way 90 degree corner joint		
5	1	PAC125-CL	1/8" Acrylic (Clear)	44.63	46.25



J150FT

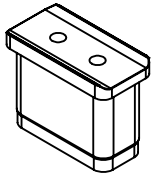

J150WT

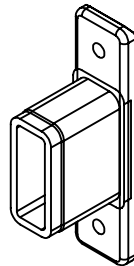

Caster - (Qty 4)

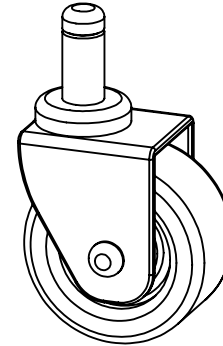

J1502L

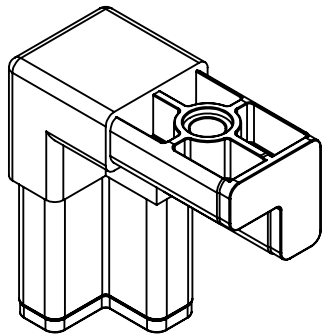

JL2150CH1A

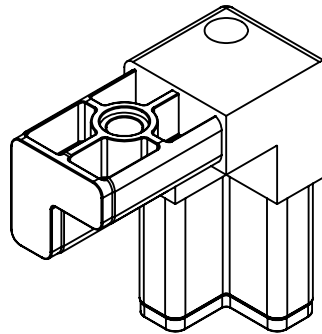

JL2150CH1A

